

T0056
PRODUCT INFO

Model name	T0056/FDN	T0056/FDH
EE article nr.	816003/00	816003/01
Gross capacity (lt)	56	56
Temperature range (°C)	> -24°C	+40°C to -24°C
Automatic cooling/heating	no	yes
Voltage	12-24Vdc	12-24Vdc
Peak Amps (@12Vdc)	9	9
Fuse on DC cord	25A	25A
External dimensions (mm)	800 x 495 x 500	800 x 495 x 500
Weight (kg)	33	33
PU insulation (mm)	70	70
"K" insulation factor	n/a	n/a
Compressor (model)	BD50F	BD50F
Refrigerant gas (type)	R134a	R134a
Refrigerant gas (gr)	65	65
Cut-out / cut-in voltage	9,6Vdc-10,9Vdc	9,6Vdc-10,9Vdc
AC/DC power supply (opt)	560019/00	560019/00
AC/DC power supply input	100-240Vac 50-60 Hz	100-240Vac 50-60 Hz

*with ambient temperature +30°C

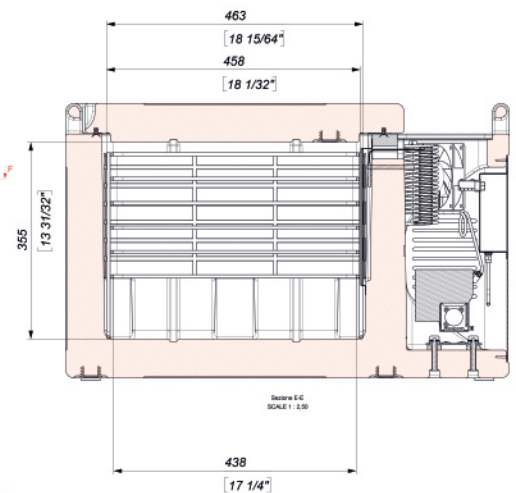
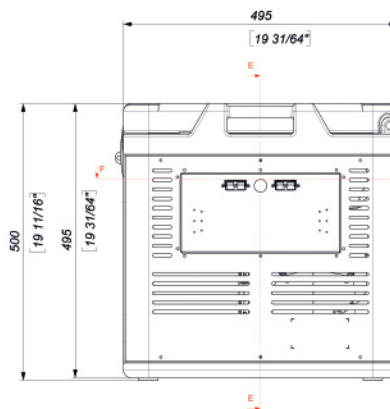
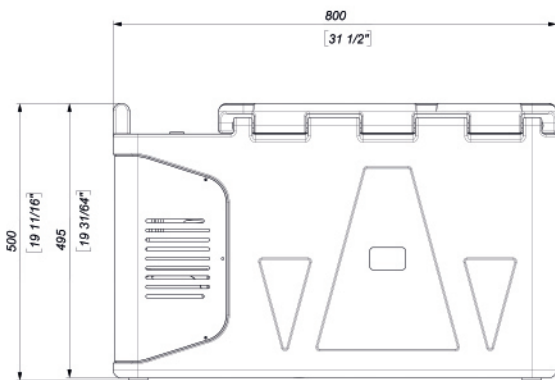

easy cooling, smart moving

www.coldtainer.com

The COLDTAINER product line includes a large range of state of the art 12V active mobile refrigerated containers. The containers are produced using the rotational molding technology according to the highest standards. They come in a variety of types, internal volumes and internal temperature ranges designed to satisfy all possible demands of professional users in term of temperature controlled transport